

In 1969, Dryvit Systems Inc. introduced Exterior Insulation Finishing System, a synthetic stucco siding, to North America from Europe where it was introduced after World War II. By the mid-1980s, the product was being used in residential frame construction. This synthetic stucco is also known as EIFS, thincoat, softcoat or PB (polymer based) stucco. It is flexible and spongy to the touch and has a hollow sound. Traditional stucco is known as hardcoat, thickcoat, cement stucco or PM (polymer modified) stucco and is brittle and sounds solid.

The system consists of:

- 1 A SUBSTRATE (SHEATHING) SUCH AS PLYWOOD, OSB OR GYPSUM BOARD
- 2 RIGID FOAM INSULATION BOARDS (EXPANDED POLYSTYRENE) ADHERED OR FASTENED TO THE SUBSTRATE
- 3 GLASS FIBER REINFORCING MESH
- 4 UP TO ¼ INCH THICK BASE COAT (CEMENT MIXED WITH ACRYLIC POLYMER)
- 5 A FINISH COAT EITHER SPRAYED, TROWELED OR ROLLED ON WHICH PROVIDES COLOR AND TEXTURE

The most important aspect of EIFS is its performance is its ability to keep water out. In Europe the system was applied to a masonry or concrete-based sheathing such as concrete block, brick or stone. When introduced to the North American market, very few modifications were made in its application in wood frame homes. With plastic sheeting as a vapor barrier (required by most building codes) and the minimal-breathable quality of EIFS, any water getting inside the walls remains trapped, leading to rotting of wood sheathing and structures. The problem is aggravated in areas of high humidity.

In the 1990s, homes in the southeastern U.S. began to experience moisture damage behind the walls of their synthetic stucco. The problem showed up in areas prone to heavy rains accompanied by wind. About 260,000 homeowners in the U.S. are now facing potentially serious water damage to their homes. Although the system is waterproof, windows, doors and their trim are not waterproof. In some homes, water has leaked behind the stucco and been trapped, causing damage – particularly around windows, doors and deck connections.

There are some lawsuits pending, but the product itself was not found to be defect; rather far too many shortcuts had been taken during its application relative to sealing and flashing. Since 1997, manufacturers have been offering a “**water-managed**” (drainable) system to the residential construction market in response to new local building code requirements *and growing consumer demand for these products.*

A visual inspection cannot determine the amount of water penetration nor damage to the substrate. A non-evasive scanner will identify areas of excessive moisture but it may not read the exact moisture content. An invasive probe meter is a more reliable method of testing. Typically about 20 to 50 probes are required. Each probe consist of two 1/8 inch holes about 1 inch apart. The holes must be sealed with an approved sealant.

VISUAL SIGNS OF POTENTIAL PROBLEMS:

- **CRACKS IN THE EIFS DRESSING BANDS AROUND WINDOWS**
- **SWELLING, CRACKING AND/OR ROTTING OF WINDOW/DOOR FRAMES**
- **DELAMINATION OF THE EIFS FROM THE SHEATHING**
- **STAINING, MOLD AND ALGAE ON THE EXTERIOR AND INTERIOR**
- **CRACKING, PEELING AND BLISTERING OF PAINT**
- **INCREASED LEVEL OF HUMIDITY IN THE HOME**
- **INFESTATION OF PESTS (ANTS AND/OR TERMITES) THAT NEST IN THE MOIST SHEATHING OF THE HOME**

MAINTENANCE ITEMS:

- ENSURE THAT WINDOW/DOOR FRAMING HAVE BEEN CAULKED TO ABUTTING CLADDING
- ENSURE THAT THERE IS NO SEPARATION OF WINDOW/DOOR FRAMES AT THE CORNERS
- ENSURE THAT EXPANSION JOINTS ARE FLEXIBLE AND WATERTIGHT (SHOULD BE ½" TO ¾" WIDE)
- ENSURE PENETRATIONS, ATTACHMENTS AND TERMINATIONS HAVE PROPER SEALANT JOINTS AND FLASHING
- ENSURE THAT ALL FLASHINGS ARE FUNCTIONAL FOR PROPER DRAINAGE AWAY FROM AND OFF THE ROOF
- GUTTERS AND DOWNSPOUTS SHOULD BE PROPERLY SLOPED AND CLEANED REGULARLY
- ENSURE THAT THE FOAM DOES NOT TERMINATE BELOW GRADE (IT SHOULD BE 6-8 INCHES ABOVE GRADE)

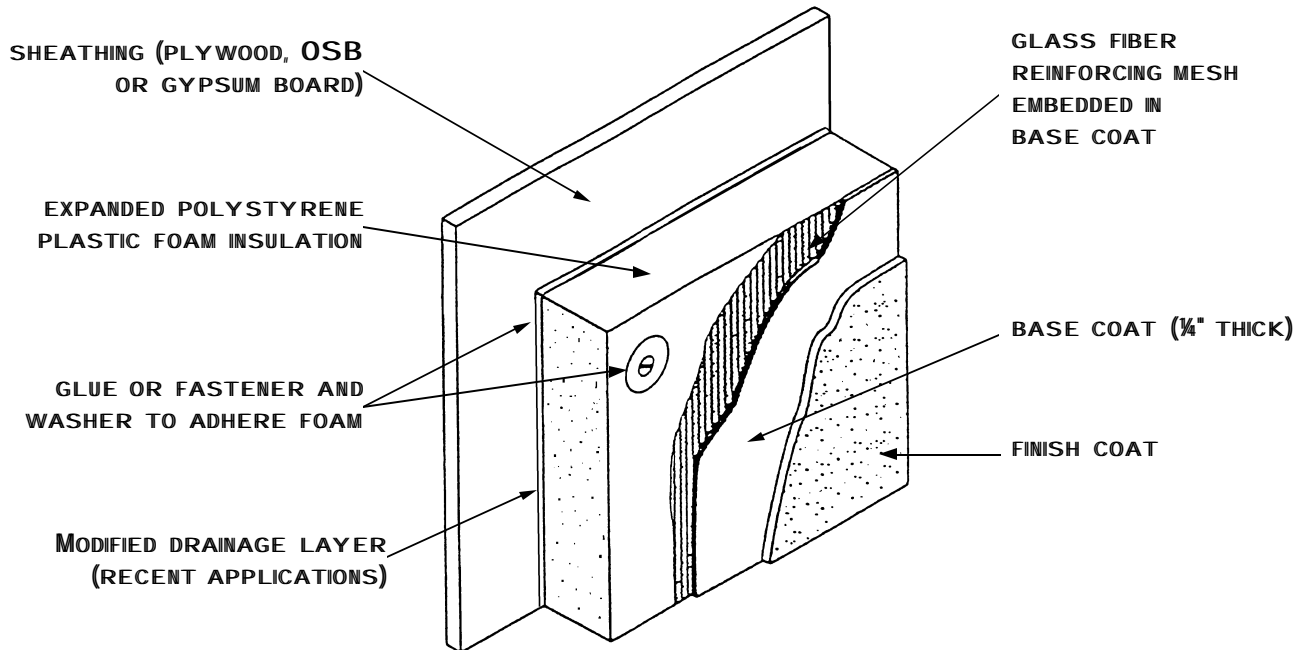

Components of an EIFS wall system.

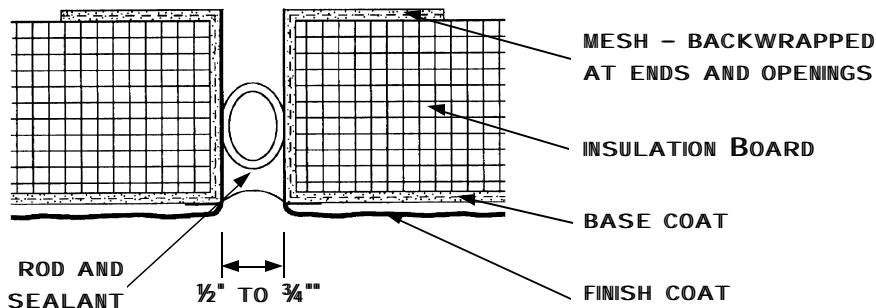

Joint Detail

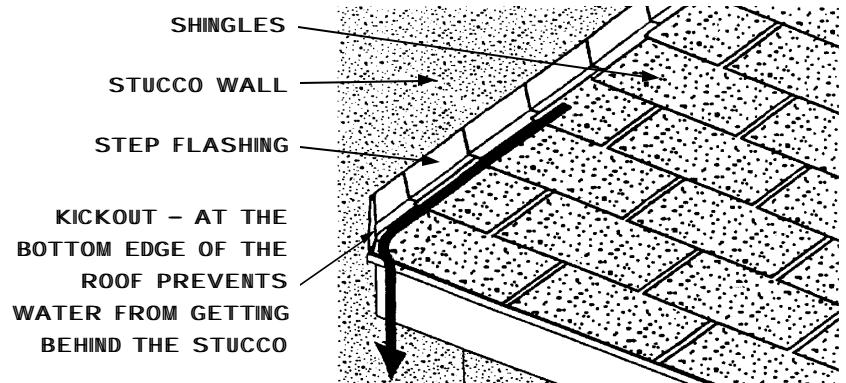

Kickout (flashing) Detail.